

Since 1990

HOW TO CONTACT THE FUNTIMES

Editorial Offices

8811 Huff Ave NE.
Salem, OR 97303

Letters to the Editor

The Fun Times welcomes all readers written comments, questions, and suggestions regarding any aspect of the Newsletter. We reserve the right to edit your letter and all letters must include your name, address and day-time telephone number. Direct all correspondence (by mail or electronically) to Letters to the Editor.

Automated Batting Cages

Phone

(503)390-5714

(800)578-2243

Fax

(503)390-4974

E-Mail

info@battingcages.com

InterNET

http://www.battingcages.com

J&J Amusements, Inc

Phone

(503)304-8899

(800)854-3140

Phone Extensions

Parts Department: ext 1

Sales Department: ext 2

Service Department: ext 3

Fax

(503)304-1899

Email

info@jjamusements.com

InterNET

http://www.jjamusements.com

Editor-in-Chief

Dick Hall

Layout Design & Graphics

Eric Hahl

Contributing Editors

Leon Wilbanks, Doug Spray, Jim Peper, Dan Hansen, Marvin Foster, Kevin Bell, Darrin Lenz

Blaster Boat Slip Ring Design

From article on cover

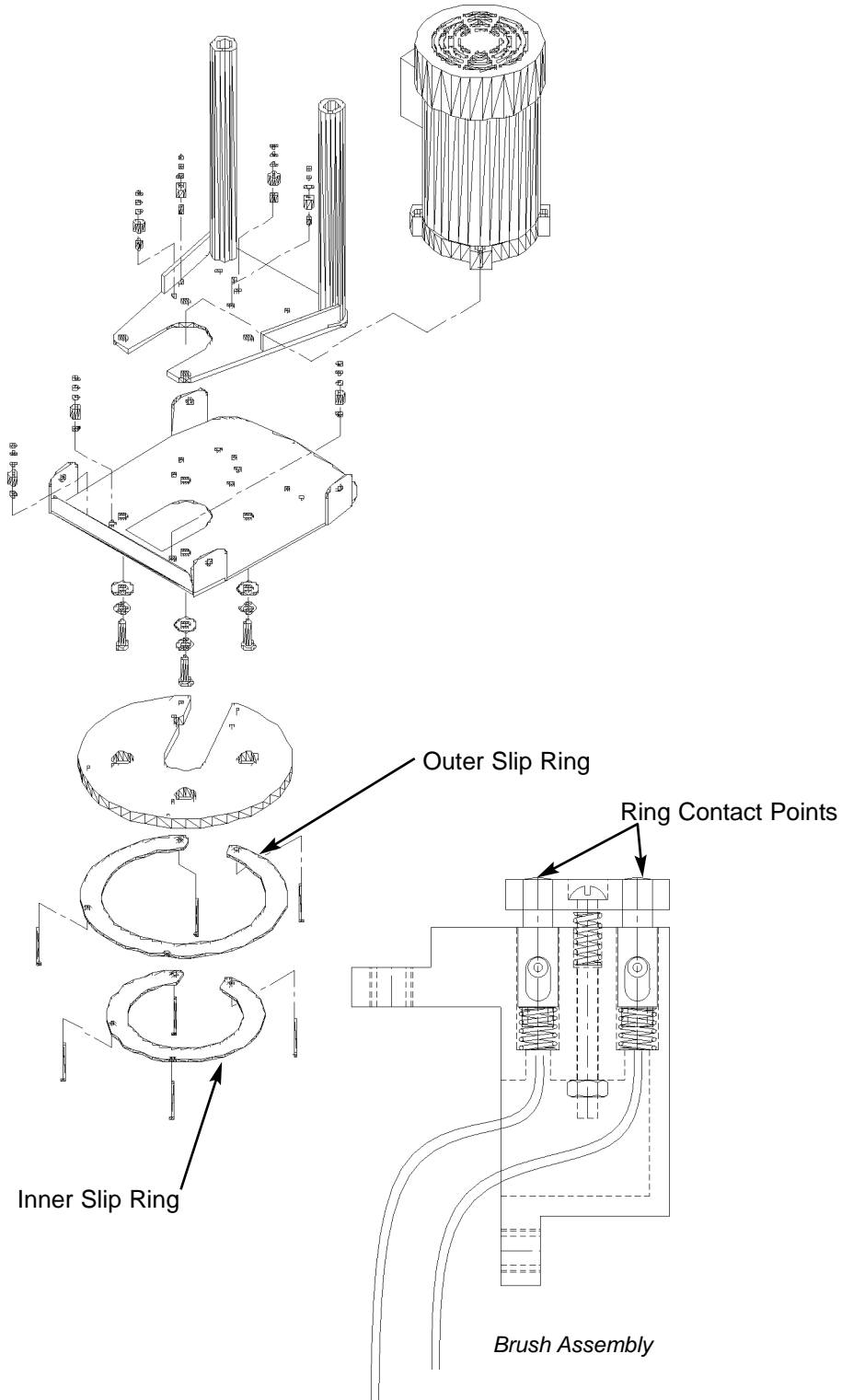

ASTM Task Group developing standards for bumper boat pools.

By Wally James

The ASTM F-24 Committee for Amusement Rides and Attractions has established a task group to address water quality standards and treatment procedures for water based amusement attractions. This includes bumper boat pools.

The committee acknowledges there is no need for and there would be substantial hardship if traditional swimming pool standards were applied. There is a need to maintain water quality, which will not make people sick or die if they should get water in their mouths by splash, finger licking or any other method. Additionally there is a need for water to be reasonably clear in view of some prior history.

The standard is in its early stages of development but the intended goal of the task force is quite clear. Amusement ride water shall have a maintained residual free chlorine level and the water shall be clear enough that the bottom of the pond is clearly visible. These goals are easily attained and are not in conflict with good and established industry practices. Clean, clear water is an asset at any bumper boat pond and can be achieved without a lot of mystery or snake oil.

Here's a procedure that'll put you in stride with practices at the better FEC's and a step ahead of the lesser lights. Don't use it if you have fish in your pond.

First use a descumner, surfactant, or enzyme to get rid of the oil on the surface. Go a step further and clean the oil off the sidewalls at the scum line. This should be a regular ritual for many reasons.

With a cheap (less than \$10 at K-Mart or Walmart) test kit, a couple of gallons of grocery store bleach (yep..Chlorox, Prox or generic bleach), and a gallon of muriatic acid (sometimes called concrete acid at Home Depot) you can come pretty close to providing safe water. Use the test kit to check the pH of the water. If the pH is between 7 and 8 you're in good shape. If its over 8 add a pint of acid for each 30,000 gallons in the pool and check again in a couple of hours after the boats have been running. If it's under 7, add about ¼ pound of sodium carbonate (called pH Up at a swim pool dealer) and test. When the pH is in the right range (7 to 8) you can move on. Once you get to adding bleach to the pool you probably won't need any more sodium carbonate so don't buy a 50# tub of it.

Use the test kit to see if there's any free chlorine in the water. You might get a surprise if you're on city water, which

often comes in at 1 or 2 ppm. If there's no chlorine in the pool, dump a gallon of bleach into the pond for each 30,000 gallons you have. Wait about 2 hours and test it for chlorine level. If there's less than 1 ppm do it again and repeat the process until your test kit shows about 2 or 3 ppm.

Once you get the pH and chlorine in range, test daily in the early afternoon and add chemicals as needed.

Turbid (dirty or cloudy) water is another issue. You must be able to clearly see the bottom of the pool. Unless you want to install a filter system and pay the operating costs, your best bet is to dump all the water out of the pool and re-fill it. Water really is pretty cheap. If your pool is sand bottom, you're on your own because you'll probably never get it clear.

There's another aspect of pool water chemistry called water balance that affects your engines, pool walls and that stuff but it doesn't affect human health. In a future article we'll talk about things like total alkalinity, calcium hardness and saturation index which can affect engine and component rot....this too can be controlled.



Once you learn the basics and get things stabilized, the job is easy. No more than 10 minutes per day for most and maybe a gallon of bleach and a quart of cement acid per week in cost.

Wally James is chair of the World Waterpark Association Safety Committee and sits on the ASTM F-24 Committee for Amusement Rides. Through his consultancy, Con-Serv Associates, he is heavily involved in technical and litigation support for the theme park and FEC industries. Most recently he provided technical assistance in the tragic e-coli outbreak which struck an Atlanta area waterpark. Wally can be reached at conserv1@mindspring.com

NOISY and VIBRATING MACHINES?

The Pitching Machine is the heart of the batting range. Maintenance, servicing, and operating instructions are described throughout various sections of your Operation and Technical Manual. As we all know a noisy or vibrating machine is sometimes difficult to pinpoint. Below I have made a troubleshooting guide (Problem, Cause, How to check, and solution) for the most common problems on noisy and vibrating machines.

PROBLEM	CAUSE	HOW TO CHECK	SOLUTION
1) Pitching machine is noisy	1a) Drive belt on machine is worn or frayed.	1a) Remove belt guard and inspect drive belt for cracks or wear.	1a) Replace with new drive belt from ABC. (part# 065)
	1b) Bearing in idler pulley is bad.	1b) Listen for constant "howling" noise. If present unplug power cord from light box. Remove belt guard then remove belt. Spin idler pulley. Grinding noise would indicate bad idler pulley bearing.	1b) Replace idler pulley.(part# 070)
	1c) Wheel shaft bearing is worn.	1c) Turn machine on, stand behind machine and listen for any loud grinding noise from your top and bottom bearings. Check for excessive "play" in bearing.	1c) Replace bearing. (part# 014 or 015)
	1d) Incorrect wheel Spacing on machine.	1d) Turn machine on, when machine is pitching balls listen for a loud thump or bang.	1d) Make shaft spacing adjustments. Refer to page 47 in your Operation and Technical Manual.
	1e) Variable speed pulley worn or loose.	1e) Listen for clicking or loud clattering noise. Check variable speed pulley for wobble. Pulley halves are keyed together. Check for excessive play between halves.	1e) Tighten or replace variable speed pulley. (part# 060)
2) Pitching machine is vibrating	2a) Wheel shaft is bent.	2a) Remove wheel and turn shaft by hand. Look at the end of the shaft for any out of round motion.	2a) Replace wheel shaft.(part# 020)
	2b) Wheels on machine are out of balance, (harmonic imbalance)	2b) Test balance by turning on machine with only one wheel at a time. Excessive vibration could indicate out of balance wheel. Vibration can sometimes be reduced by changing speed slightly.	2b) Replace wheel or return to ABC for re-balancing. (part# 010)
	2c) Drive belt on machine is worn or frayed.	2c) Remove belt guard and inspect drive belt for cracks or wear.	2c) Replace with new drive belt from ABC. (part# 065)
	2d) Wheel wobble.	2d) Remove belt cover and drive belt. Slowly spin wheel by hand and look for excessive side-to-side movement.	2d) This occurs when wheels are not mounted properly and causes the wheels to wobble side to side. Remove wheel, flip shaft collar around and make sure all mating surfaces are clean, then remount wheel. If wobble still exists, replace wheel.
	2e) Variable speed pulley worn or loose.	2e) Remove belt guard and belt, turn machine on and look for wobble on your variable speed pulley.	2e) Tighten or replace variable speed pulley. (part# 060)

SAFETY ALERT

Reason For Release: Reported incident. Short circuit of white and black wires downstream from batteries may cause melting and/or burning of insulation.

Action To Be Taken: Install in-line 100-amp fuse using fuse and stainless steel hardware provided by J&J (kit part #2-70-0001). Remove white 10ga wire from positive battery terminal (goes to motor), install fuse following drawing provided in Detail section of this bulletin. Reattach white 10ga wire to fuse using stainless steel 5/16 bolt nut and

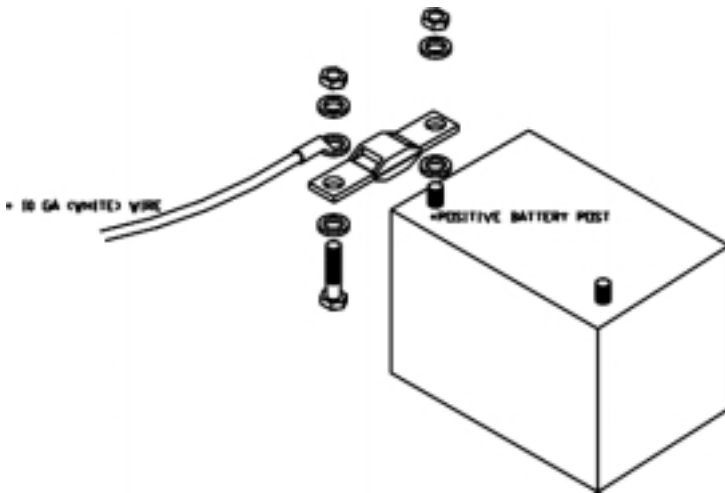

washers provided. **DO NOT BEND OR APPLY UNDO PRESSURE TO THE FUSE.** Using a voltmeter check for power through the fuse before putting boat back in service. Treat all connections and terminals with Corrosion Block Spray part # 99101 or equivalent.

Always advise your pond attendants to remove boat from service if the motor exhibits intermittent operation during a ride or wire harness/connector gives any indication of getting hot.

Problem: Intermittent motor operating and/or high heat and melting of connectors or main harness. In extreme cases can cause fire and burning of wire insulation.
Cause: Movement of main wire harness will eventually cause wire breakage inside the insulation jacket. Partial separation of wire inside the harness may cause excessive heat due to resistance without causing fuse to blow.
Action To Be Taken: Checks: Daily manual check - tie boat off securely. Point motor toward dock and hold down power "on" button (tape can be used to hold button down temporarily for test). Carefully feel wire harness from motor to hull checking for hot spots that would indicate an area of high resistance. With motor still running wiggle and bend the harness paying special attention to areas around the connector clamp and through hull strain relief. Intermittent

motor operation at any time indicates a connection or wire problem.

Corrective Action: Repair or replace wire or connectors as needed. Use corrosion block grease (part #3-60-0002) or similar dielectric grease on the backside of SB50 (gray) connectors as well as connections themselves to help stop corrosion. Wire terminal ends for the SB50 connectors can be replaced (part #01413). These can be soldered or crimped on to the 10-gauge wire. A good method here is to have a spare harness so they can be replaced, then repaired for reuse.

Always advise your pond attendants to remove boat from service if the motor exhibits intermittent operation during a ride or wire harness/connector gives any indication of getting hot.

Do your Go-Karts Leak Oil?

J&J has found a better seal! Viton® is well known for its excellent (400°F/200°C) heat resistance. Viton offers excellent resistance to aggressive fuels, oils, chemicals and has worldwide ISO 9000 registration.

These seals are designed to resist the high temperatures that Concession Go-Karts have to endure. We have seals that replace the clutch output seal (the most common leak point) and we also have engine case seals.

To meet your State and ASTM F24 guidelines you should not operate any Go-Kart with oil leaks.

Give us a call or e-mail.

Seal, GX Output Shaft High Heat (Viton) (Replaces Honda Part#00651360)

Part # 10006 \$7.12 each.

Seal, Reduc. Input Shaft High Heat (Viton) 5-6.5hp (Replaces Honda Part#06369360)

Part# 10007 \$8.95 each

Seal, Reduc. Input Shaft High Heat (Viton) 8-9hp (Replaces Honda Part#07564940)

Part# 10008 \$12.20 each

Ultimate Oil Sucker

Are your mechanics changing the oil every 100 hours or weekly for a normal Go-Kart Track?

To comply with today's exacting environmental guidelines, the Ultimate Oil Sucker makes removing oil from go-karts, bumper boats and other small engines safe, clean and easy! With an all aluminum cart design, this unit is lightweight, high strength, and is easily mobile. It uses an air operated, non-metallic diaphragm pump which offers high-volume delivery even at low air pressures, easy self-priming, and the ability to pump oil of various viscosities. The air operated double diaphragm pumps utilize a pressure differential in the air chambers to alternately create suction. It has a 10-gallon capacity that's enough capacity for approximately 30 go-karts. It's a great way to change your oil!

Oil Sucker (comp. air operated crankcase evacuator)

Part # A01103 \$499.00

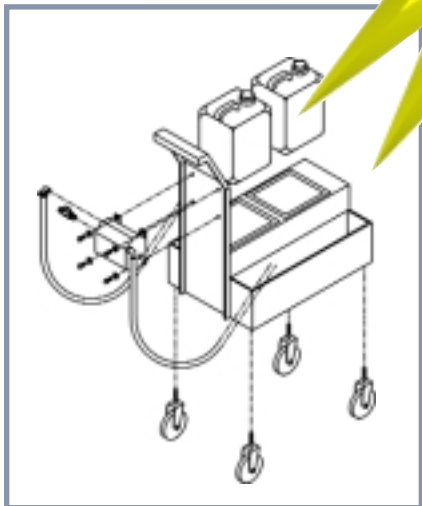

Oil Dispenser

The air operated oil dispenser makes oil changes fast and clean. This dispenser comes equipped with a 6.3-gallon tank and digital quart calibration valve meter with flex spout. Flow can be set at 1-26 quarts per minute with a pinpoint accuracy. Shuts off at the tip and eliminates spillage. This unit is accurate down to .100 Qts. We use it at J&J's factory. It's quick, accurate and clean!

Oil Dispenser, 6.3 Gal (W/Meter)

Part # 011050 \$495.00

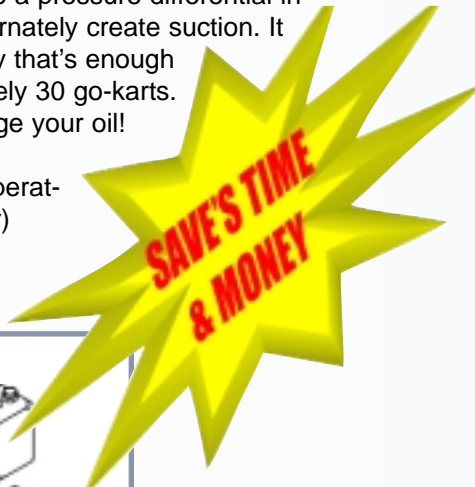

LED Pitcher

Well, the Seattle Mariners might have their Japanese hero, ICHIRO but we've got "LED San". (LED equals Light Emitting Diode- cool huh).



After studying the LED pitcher manufactured in Japan during last fall's IAAPA show, we decided to check this thing out and see what it can do. We purchased a test unit and played with it in the shop during the winter. With

only one small glitch that we fixed with no difficulty, it worked great. We installed the pitcher at our Beaverton (Oregon) Batting Cages operation in May. So far it has worked with no problems and it has been a hit at the cage.

The first day we called up ole' LED San, a Dad and two sons dropped by to check it out. They spent \$45.00 playing with it! That's a good start. We'll keep you up to speed with how it works and what excitement it generates.

The LED Pitcher imitates with the ball drop from the pinch roller, he winds up and follows through (throws) as the ball exits the ball chute. Adjustments can be made to speed up or down the "wind up" - this allows you to time the ball drop to its exit point. Other adjustments include "arm speed" - to alter the speed of the pitch. We are using it on a



Continued on page 7

medium speed because we figure everyone wants to try it and we didn't want it too fast. It really looks great and the timing is perfect. We don't charge extra to play it

The concept we like - The price, we don't like. It's like \$9,000 each, without installation! I can buy a darned good used Honda for that kind of dough. They are quite the hit in Japan, however. Most of their cages are indoor and a round of balls can run 5 bucks! Perhaps adding them could increase revenue?! Anybody interested in purchasing a dozen, let us know. We'll put a video on the internet and you can see for yourself. Check it out under our products section at www.battingcages.com.

Soccer Equipment Intro

The soccer revolution has arrived in the United States. In recognition of the increased popularity of soccer and in answer to numerous customer inquiries, ABC has developed a new coin operated soccer system. From the Soccer Automatic Retrieval System to the rugged ABC "Kicker" pitching machines, this system is built with the same attention to dependability and operational performance that has made ABC the leader in the coin operated batting cage industry.

The Soccer Automatic Retrieval System can provide constant, trouble free ball distribution. Customers can choose from the standard "SA-3" stand alone electronics or optional Master Office Control Panel for remote operation. The soccer "Kicker" machine follows the time proven design and technology of our present pitching machines. Of course, all other related equipment conforms to the high level of quality that our ABC operators have become accustomed to.



The Kicker

Designs and construction prints are available for cages with 2 thru 5 stalls. Custom designs are always available for that "one area" that doesn't work for any other attractions.



Sign Mounting Brackets

A long overdue accessory that is now available are warning sign mounting brackets. Crooked signs are definitely detrimental to your cage appearance. The bracket is manufactured using formed steel with a tough white powder coat finish. After mounting the warning sign to the bracket, the assembly is securely clamped to the chain link fence. The bracket provides rigidity to the signs and allows for level and plum installation. Price for the 24" X 36" sign bracket assembly is \$50.00 each with the 35" X 46" bracket assembly priced at \$65.00.



BIGFOOT™
**More Meat,
 Less Money!**

NOW ONLY \$10.99 each

In Quantities of 1 or a BILLION!
NO MINIMUM QUANTITY REQUIRED FOR THIS GREAT PRICE

J&J Amusements
 has done it again!
 We've bettered our Bigfoot Tire!

J&J Amusements, Inc.
A CORPORATION OF OREGON
 4897 Indian School Rd NE 503-304-8899
 Salem, OR 97305 USA 1-800-854-3140
 E-mail: parts@jandj.com FAX: 503-304-1899

We sell genuine parts for Honda go-kart, industrial and marine engines.
 For more information, call or write us at the address listed above or visit our website: <http://www.jandj.com>

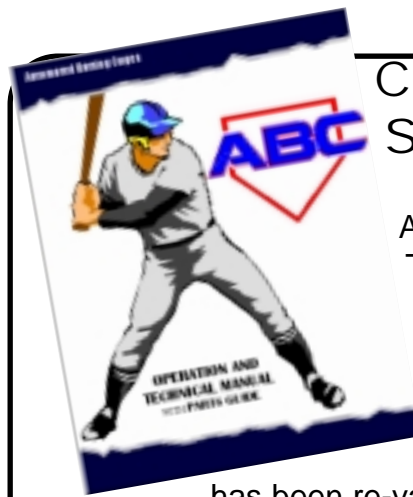

**Coming
 Soon!**

ABC's new Technical & Parts Manual has been updated to include all our new products. Our Technical Guide has been re-vamped and includes an Up-to-Date "How to" section. Also, ABC has developed a new Training Video for you and your employees. This video is a must to keep your employees Up-to-Date with the latest Safety Training and Operations Procedures.
 Best of all...Its FREE! Thats right, ABC feels so strongly about safety in the batting range that we are sending you the new manual and video for free. Look for them to be shipped via UPS soon.

FUNTIMES

4897 Indian School Road NE
 Salem, Oregon 97305



PRST STD
 U.S. Postage
 PAID
 Salem,OR
 Permit No. 472
