

# The Fun Times

NEWSLETTER

Your Guide to Amusement Industry Products and Services by Automated Batting Cages/J&J Amusements

Winter 2001

## HIGHLIGHTS THIS ISSUE

E-Commerce  
(cover)

On-Line Tid Bits  
(page 2)

ABC Tech Talk  
(page 3)

J&J Tech Talk  
(pages 4 & 5)

Safety Issues  
(page 6)

New Stuff  
(page 7)

SEND US YOUR E-MAIL ADDRESS!

## The "E" Times..

When I was growing up "E" stood for Elvis but times change...Now, "E" stands for Business! Is this a good thing?

What can you find on our websites? Our new websites provide easy-to-use menus that allow you to find the information you seek, instantly search everything from Service information to

new and existing products to ordering parts and supplies online. ABC's "TechWEB" and J&J's "Service" areas will include many technical illustrations along with maintenance and operational procedures.

Visit our sites today and keep informed with all the latest information, service and safety bulletins.

Encourage your technicians to review our service and techweb areas for useful tech tips and more. Welcome to the "E" World!

No...It's a very good thing! Never before have we been able to provide instant world-wide service and information to our customers.

This is an excellent time to offer a very special thank you to Dan Hansen at www.jjameusements.com and Eric Hahl at www.battingcages.com for taking on our respective website projects 6 years ago. Having the motivation and foresight to embrace this technology and spending untold hours to make it a reality is an accomplishment that deserves special recognition. So...Thanks Dan and Eric-I'll bet you never envisioned what this would be when you bought that first web publishing program.

## ..E-Commerce and its future with ABC and J&J



Since 1990

## HOW TO CONTACT THE FUNTIMES

### Editorial Offices

8811 Huff Ave NE.  
Salem, OR 97303

### Letters to the Editor

The Funtimes welcomes all readers written comments, questions, and suggestions regarding any aspect of the Newsletter. We reserve the right to edit your letter and all letters must include your name, address and daytime telephone number. Direct all correspondence (by mail or electronically) to Letters to the Editor.

### Automated Batting Cages

#### Phone

(503)390-5714  
(800)578-2243

#### Fax

(503)390-4974

#### E-Mail

info@battingcages.com

#### InterNET

http://www.battingcages.com

### J&J Amusements, Inc

#### Phone

(503)304-8899  
(800)854-3140

#### Phone Extensions

Parts Department: ext 1  
Sales Department: ext 2  
Service Department: ext 3

#### Fax

(503)304-1899

#### Email

info@jjamusements.com

#### InterNET

http://www.jjamusements.com

### Editor-in-Chief

Dick Hall

### Layout Design & Graphics

Eric Hahl

### Contributing Editors

Leon Wilbanks, Doug Spray, Jim Peper,  
Dan Hansen, Marvin Foster, Kevin Bell,  
Darrin Lenz

## Save Money! Order On-Line

You can now save \*\*2% on orders placed using J&J's Online Catalog Store or Online Quick Database Store.

### Benefits To Online Ordering:

Save 2%

It's Easy to Use

Part Numbers are always up-to-date

Prices are always up-to-date

Your order is always readable

### How To Order Online?

Just go to

<http://www.jjamusements.com> and click on the blue tab at the top of the screen that says Parts Dept. It will



then take you to the Parts Department section of our web site. Select either the Online Catalog Store or Online Quick Database Store. Specific instructions for each store are located in those areas.

What is the Difference between Online Catalog Store and the Online Quick Database Store?

Online Catalog Store is arranged in categories and sub-categories. Just browse thru the categories to find your specific item or items.

Online Quick Database Store can be easily searched using part numbers or descriptions.

All Parts Guides are available online.

Visit:

<http://www.jjamusements.com> for all latest news, parts guides, service manuals, service instructions, and service bulletins.

\*\*To qualify for the 2% discount, you must use J&J's Online Catalog Store or Online Quick Database Store. There will be no discounts on fax

orders, phone or other type of ordering methods. Excluded Items: Tires, Bumper Boat Tubes, Inner Tubes, Engines, Short Blocks, Battery Chargers, Drive Belts, Complete Karts & Boats and Special Order Items. Specifications are subject to change without notice.

## Tracking & Calculating UPS Shipments To Your Park

Have you ever wondered where your parts shipment is, or how much it will cost to ship parts to your park? If so then the UPS website is your answer. At [www.ups.com](http://www.ups.com) you can use the Quick Cost Calculator to estimate shipping for Next Day, 2nd Day, 3rd Day and Ground shipments. Also located on the UPS website is the Track feature, from here you can view the progress of your shipment. If you know the tracking number of your package you can see where it is, when it is scheduled for delivery or who signed for the package if it has already arrived.

If you want to know the tracking number for your shipment, email J&J at [parts@jjamusements.com](mailto:parts@jjamusements.com) or ABC at [info@battingcages.com](mailto:info@battingcages.com) and we will reply with the tracking number of your package.

Send Us your e-mail address, If you have an e-mail address write J&J at [info@jjamusements.com](mailto:info@jjamusements.com) or ABC at [info@battingcages.com](mailto:info@battingcages.com) and let us know, this will aid in future shipments.

Starting near the end of February, J&J will send all customers with e-mail addresses the tracking numbers of their shipment. There will be no need to contact us as this will be an automated process upon shipping. Until that time you will need to request the tracking number and we will send the information via e-mail.



## OPENING DAY!

The new 2001 Batting Range Season is about to begin and this is the time to prepare your batting cages for opening. In

this Funtimes issue we would like to highlight a few areas that we recommend you pay particular attention to:

1.) Visibly inspect your baseballs and softballs. Check all balls daily. Remember, even if the dimples are still visible and the balls appear useable, cracking and breaking are indications they are at the end of their life! If balls have any cracks we strongly recommend you replace all of the balls in the system. Also check balls for wear (dimples that are worn to 50% dimension of their original size). Remember, you cannot mix new balls with old balls. The difference in ball size will cause inaccurate and erratic pitching. We have found that ball condition can have a significant impact on the accuracy of the pitch.

2.) Check all batting helmets for wear or breakage. Make sure the facemasks are securely fastened to helmets and the padding is in good condition. Replacement padding and protective facemasks are available from ABC. If your helmets are several years old or are unsightly, replacing them with new helmets should be considered. Batters like using new, fresh looking helmets! Remember: All Batters Must Wear Helmets with Faceguards At All Times!

3.) Check Net rings (ball exit hole frames) for proper alignment. It is important that the balls pitch through the center of the net ring. Balls should not pitch near one side or the other of the net ring. Verify by watching several pitches go through the ring. This adjustment should be checked on a daily basis during the season. Make the necessary adjustments to the netting and the ring before allowing use of the cage. (See page 44 of your ABC Operation and Technical Manual).

4.) Follow all general maintenance procedures of the machines and the batting cage area as covered in the ABC Operators Manual. Follow all safety procedures as detailed in the ABC Operators' Manual. Refer to this manual as you prepare for the New Year.

5.) We would like to highlight one important maintenance procedure and adjustment in this TechTalk issue. This procedure and adjustment focuses upon the ball-viewing chute adjustment and it's relationship to the 90-degree drop. After setting the machine to the desired speed and trajectory, you must check the angle of the ball-viewing chute. There must be slope angling downwards towards the wheels (gravity allows the ball to roll towards the wheels). The angle must be steep enough that a ball always rolls toward the wheels. If the machine needs to pitch higher, the machine will need to tilt backwards, decreasing the angle of the ball-viewing chute and the balls may not roll to the wheels. After determining the desired speed and trajectory of each machine and adjusting the ball-viewing chute (to allow for balls to roll down to the wheels) verify that the balls exiting the 90-degree drop (after release from the pinch roller) fall into the ball-viewing chute. The ball "drop" should be no less than 3.5 inches for

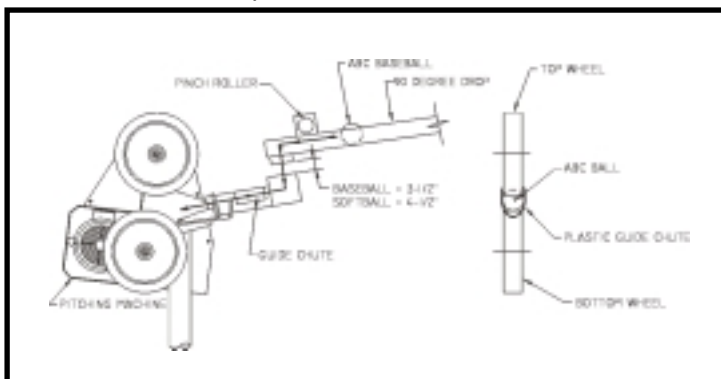

a baseball and 4.5 inches for softball. The 90-degree drop should never be resting inside of or touching the ball-viewing chute.

6.) Review all Warning and Instruction Signs. Make sure they are legible, up to date and located where they are convenient to read. One easy method to refresh the appearance of your batting cages is to replace your old signs with new signage.

Let the season  
begin!

## J&J Go-Kart Throttle Cable Adjustment

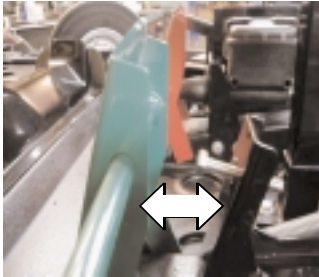

1. Begin by setting the speed on your kart. All speed adjustments(see the workshop manual for proper procedure) should begin by the pedal stop located behind the gas pedal. By screwing the bolt inward you will make the Kart faster, by screwing the bolt outward it will slow the Kart down.

\*\*All Karts should be set to equal speeds for safety. Two people may be needed to set speed correctly. Speeds can be set by either using a tachometer or more accurately with a MPH gauge.

\*\*J&J Wireless Tachometer Part Number 01099

\*\*J&J Digital MPH Gauge Part Number 1726

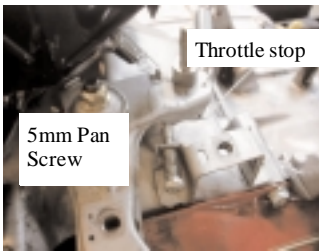

2. While setting the speed pay attention to the Engine throttle stop, the throttle will open as far as the Engine stop allows. Once the Speed has been set make sure when the gas pedal is fully depressed the throttle stop is resting at the 5mm pan screw. \*\*When the throttle pedal is fully depressed and the inner throttle cable should not be tight, the throttle should be open up to the 5mm pan screw, it should not be forced against it. Damage to cable assembly, throttle assembly and throttle pedal may occur if cable is still pulling when rested against throttle stop. This does not apply to cables that are pulled via a spring override.



3. If there is not enough room for full throttle before cable hits housing, or too much throttle as described in above section, the housing will need to be adjusted. Throttle cables have adjustment at both ends, make all adjustments at engine side. Loosen the jam nuts and move the housing closer to the throttle arm to decrease the amount of throttle pull, move the cable away from the throttle arm to increase the amount of pull. Tighten jam nuts when completed.



4. When all adjustments are complete, double check all jam nuts to be sure they are tight. Blue locktite can be used to be sure jam nuts will not move.

\*\*Warning: Screwing pedal stop screw in without following other adjustments will cause entire force of throttle pedal action to place excessive damaging loads on throttle inner cable and throttle linkage.

## Safety and Service Bulletins Available 24/7/365

Just go to <http://www.jjamusements.com> and click on the blue tab that reads Service Dept. at the top of the page. Once in the service section, just click on the: Service and Safety Bulletins. All Bulletins are listed by product, date released and posted in Adobe Acrobat Reader Format. If you need a PDF viewer you can download a free copy at the top of the page, just follow the instructions listed on the page.

Does your maintenance person work nights and have a question? Just E-mail your question to: [Service@jjamusements.com](mailto:Service@jjamusements.com) for the answer. The Service section of J&J's web page is open 365 days a year 24 hours a day and new information is being added all the time.

# How to Properly pack Tapered Style Wheel Bearings



1.) Begin by removing the dust cap, using Channel Locks grasp the dust cap firmly and work up and down while pulling outward as well. Remove the cotter pin and castle nut set aside the castle nut and dust cap. Throw away the cotter pin, it will not be re-used.



2.) Remove the Wheel Bearing Seal, wipe off the excess grease from the Wheel Bearings as well as the Hub Assembly. (do not use solvent to clean the Bearings) Inspect the Wheel Bearings and the Bearing Races for pitting or excess wear and replace as needed. Throw away the Wheel Bearing Seal, it will not be re-used.



3.) Pack Wheel Bearings with Wheel Bearing Grease either by hand or with Wheel Bearing packing tool, forcing grease into the cage and roller assembly. Put a film of grease on both Wheel Bearing Races and on the Spindle shaft.



4.) Install rear Wheel Bearing and rear Wheel Bearing Seal. Use a large seal installation tool to avoid damaging seal.



5.) Put a light film of grease around the lip of the Grease Seal to keep it from tearing during installation. Wipe off the excess grease prior to installing.



6.) Install the front Wheel Bearing and castle nut, torque the castle nut to 15 ft. lbs to seat the Wheel Bearings properly. Then loosen the castle nut to finger tight and rotate the Hub Assembly the hub should rotate freely. Line up the hole for the cotter pin through the castle nut by tightening the castle nut then double check that the Hub Assembly rotates freely and has no play on the Spindle.



7.) Install a new cotter pin, using a brass drift punch, tap the head of the cotter pin down into the castle nut. When complete the head of the cotter pin should be crushed just slightly.



8.) Fold the front half of the cotter pin over the Spindle and cut off the back half. Re-install the dust cover.

## SAFETY IN THE BATTING CAGES

As detailed in our "TechTalk" column, proper maintenance procedures for the equipment systems and batting cages will encourage and maximize the safety of our batting cage customers and our employees. Not only is safety important for these obvious reasons but it also has another very important byproduct: It is Good Business! Safety will not only keep your cages a safe place to play but it can also increase your revenues and your profitability! In keeping with ABC's commitment to safety in the batting cages, we would like to offer an easy method to prepare for the 2001 season. Please use this handy guide as your to-do list before opening.

### SAFETY CHECK LIST

- Do I have a current ABC Operation and Technical Manual with parts Guide?
- Do I have the ABC training video?
- Do I have a Safety Program prepared?
- Have I read the "Safety in the Batting Cages" section of the ABC Manual?
- Have I trained my new employees using the ABC Manual and videotape?
- Do all of my batting helmets have face masks?
- Are all of my baseballs and softballs in good condition?
- Do I have enough spare parts for the new season?
- Is my toolbox ready for the new season?
- Do I know ABC's phone number? (1-800-578-2243)
- Do I know ABC's e-mail address? (info@battingcages.com)

## SAFETY IN THE PITS

The Pit area of your Go-Kart track can be one of the most dangerous areas in your park, but with a little attention you can reduce the risk. Here are some things to look at plus a few tips to help you:

Entry signage: Is it where your customer can read it and in good condition?

Queue line fence, entry and exit gates: Any repairs needed? Are the queue lines long enough?

Message repeater: Set at a sufficient volume and is the voice message clear and cover all the rules? How about reminding the riders in the message not to push the gas pedal while waiting in the pit area?

Lighting: Any bulbs out? Is it adequate at night?

Pit islands: Are they clearly marked where you want your customers to go on entry and exit? Do you need gates between the islands to keep customers from climbing over the Karts?

Track signage: In good condition and set at the correct height for a customer in the Kart to read?

Track direction arrows: Are they bright and easy to see?

Traffic lights:

Operating correctly?

Bulb bright enough to see during the daytime?

Track safety equipment: Fire extinguishers charged and placed properly? First aid kit fully stocked and easy to get to?

Kart shut down: All Karts working properly and being checked daily? (Check the new "Two Wire" pit loop for kartrol systems on page 7).

Karts: All safety decals in good condition, seat belts and pads in good condition and easy to adjust?

Employee uniforms: Are they bright and easy to see at night, do they need safety vests?

Video surveillance: If you don't have a video surveillance system on your track you might think about installing one. It can be used to assist in litigation matters, monitoring for vandalism or even assessing how your employees handle incidents and how to improve those situations.

Safety is one thing that can't be over stressed; it's a good idea to have a brief meeting with your crew daily. Ask them how they would handle a made up situation or problem... invite their input, you never know when you might learn a thing or two!



## Almost New Double Thunders:

J&J has for sale, 20 almost new Double Thunders complete with 9HP Honda engines, 4.75 gallon tanks and less than 800 hours each. Comes with new kart warranty. Excellent condition!

Contact Marvin Foster at [marvin@jjamusements.com](mailto:marvin@jjamusements.com) or 1-800-854-3140.

## Bumper Boat Short Block & Motor Update:

We sold 300 of Honda's new BF2D outboard motors last year with great success. The BF2D replaces the dated BF2A in J&J's gasoline line of Bumper Boats. If you are not ready to upgrade to the best gasoline powered motor available, we still have plenty of BF2A short blocks & parts in stock.

BF2A Short Blocks: Part# 00677—Price: \$259.00  
BF2D Complete Motor: Part# 2-00-0001—Price: \$1095.00 each.

## New Kartol Product for 2001 Improves Pit Control

New for 2001 from Kartol is the double pit loop wire. The double pit loop wire gives you the ability to turn down the range while it doubles the effective control and still has the same sensitivity. With the range turned down fewer karts will shut down prior to the loop or on another part of the track and increase your tracks safety and productivity.



Twice the loop, twice the protection. Call J&J Parts department for more information. Fits all existing kartrol systems.

## NOTICE

### PRICE CHANGES

Due to the upgraded "slip ring" system that eliminates wires between the battery and boat motor and including the Squirter as standard equipment the price of the new Blaster Boat is \$2999.00 each. (this does not include charger or batteries).

Due to a large price increase of plastic and energy the price of the Gas Bumper Boat will now be \$2199.00 ea.

Kart prices remain the same while some parts prices have risen as we strive to hold the line on price.

## The "I" in Internet is for INFORMATION

What do you want to know?

Well, a good percentage of what we know is all there for you to view, once you access our web site.

Not on the web yet? Get with it. Access can be a boon to your business and personal life. The Internet is a resource that will enhance your ability to find things out. It's like having the Thomas Register, Library of Congress, the Smithsonian and thousands of other information sources at your fingertips.

You could go to [www.jjamusements.com](http://www.jjamusements.com) to find out all about J&J products. There you'll see pictures and descriptions of our go-karts and bumper boats. You can find out how big a bumper boat pond should be, based on the number of boats you want to operate. Should you choose gas or electric powered boats? How much land will you need for a go-kart track? How long should the track be? What's the best material for the track surface, concrete or asphalt? Should you build an overpass? What about remote shut-off? What kind of guardrail works best?

All these questions and hundreds more can be answered by a visit to our website at: [www.jjamusements.com](http://www.jjamusements.com).

Service and Parts information is also available there. Illustrated service bulletins can help you carry out procedures. You can even order parts from our website. We have provided this website as an "Information Site" rather than just a location to sell our karts, boats and parts.

If you have a question about karts or bumper boats and can't find the answer there, give us a call; we can help.

# Bigfoot Tire/Tube Combo

Get your Bigfoot  
tire/tube combo  
now!

**\$11.99**

While supplies last

NO BETTER PRICE

**Stock up for  
the season!**



**Amusements, Inc.**

4897 Indian School Rd NE, A, Clatsop County, Oregon 503-304-8899  
Salem, OR 97306 USA 1-800-854-3140  
E-mail: [paris@jjanusements.com](mailto:paris@jjanusements.com) FAX: 503-304-1899

## PROTECT YOUR NET!

ABC's lightweight and durable net protector can help save costly netting repairs.

Batted balls will have a damaging affect on the lower most portion of your outfield netting.

Protect your investment with this easy to install and inexpensive protector.

Our net protector comes in two sizes to protect this area, 4' tall (part #513) and 7' tall (part #516).



Call us today and order yours!

1-800-578-2243

## FUNTIMES

4897 Indian School Road NE  
Salem, Oregon 97305



---

Bulk Rate  
U.S. Postage  
PAID  
Salem, OR  
Permit No. 472

---